

EXTRUDER TEA 70.25



FLEXIBLE EXTRUSION

Modern design of our screws and barrels is perfect in a wide variety of applications in cable industry for wire insulation, cable sheathing and the extrusion of precision tubes. TEA series extruder can be also employed as an auxiliary extruder in any multi-layer extrusion process. The barrier zone screws combined with grooved barrels meets the requirements of efficient extrusion for the majority of raw materials in common use.

Extrusion output for TEA 70.25

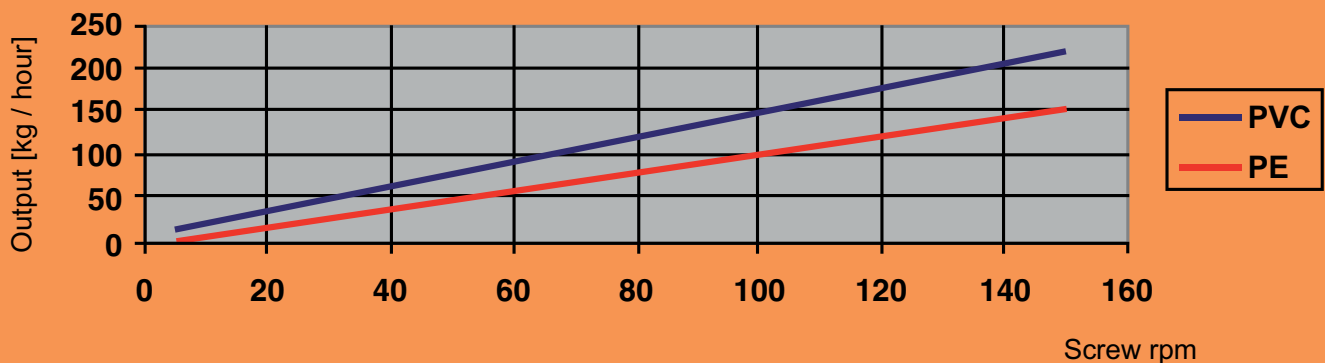

TECHNICAL CHARACTERISTICS

Screw diameter	70 mm
Screw length	25 D
Drive power AC (max)	41-70 kW / 2000 rpm
Torque (max)	6 kNm
Screw speed (max)	150 rpm
Heating zones	4
Heating power	17,8 kW / 400 V

MACHINE DIMENSIONS

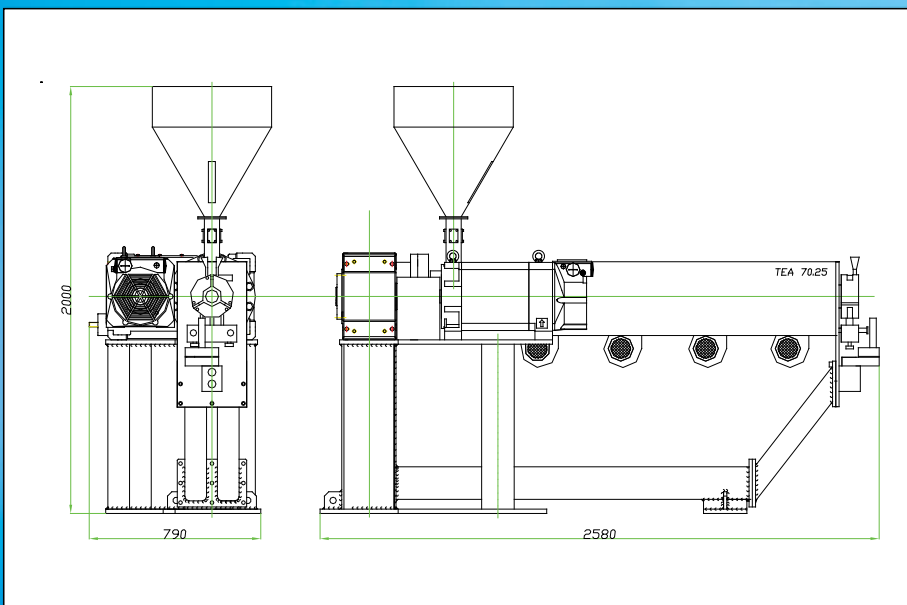

MACHINE CONTROL

TEA extruders can be equipped with control system in two options:

- operating panel SIEMENS for manual setting of extrusion parameters by operator using keyboard
- PC komputer with touch screen, mouse, pad or keyboard for parameters setting. In this case a visualisation of all extrusion parameters is currently available on the screen.

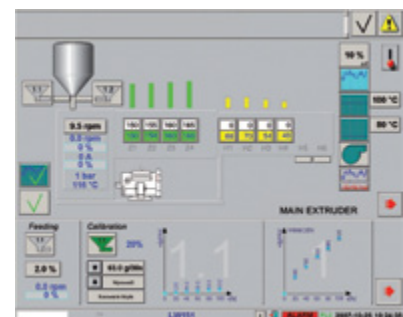

In both options the control unit may be connected to the overall line control through a PROFIBUS and synchronised with all line components by PLC